



# Airless Dryer

**Unique rotary drum dryer  
improves fishmeal quality,  
boosts processing efficiency  
and enhances safety.**

**DUPPS**

## **Improved product quality is inherent in the airless design**

- The Airless Dryer provides a much higher rate of pathogen inactivation. A recent study\* has shown that using superheated steam as the drying medium — like the Airless Dryer — has a much higher rate of pathogen inactivation than typical hot air dryers.
- Better mink digestibility — airless drying has been shown to improve mink digestibility percentages in processed fishmeal.
- Drying in an oxygen-lean environment minimizes product oxidation.
- Shorter product residence time in the dryer reduces protein degradation.

## **Greater efficiency with lower environmental impact**

- The Dupps Airless Dryer offers the highest thermal efficiency of any dryer commonly used in the fishmeal industry, up to 20% fewer BTUs per pound of water evaporated.
- Dryer exhaust is essentially water vapor, which can be used as a superior heat source elsewhere in the plant.
- Because the dryer's exhaust is primarily water vapor, emissions are dramatically reduced and there is no visible exhaust plume — features that benefit everyone.
- The airless design requires much smaller odor control and scrubbing system capacity.

## **Combustion isolated from the drying loop**

- The oxygen-starved environment reduces the risk of in-drum fires and dust explosions.

\*Visit [www.dupps.com](http://www.dupps.com) for study details.

# Airless Dryer

Unique rotary drum dryer boosts fishmeal processing efficiency, improves product quality and enhances safety.

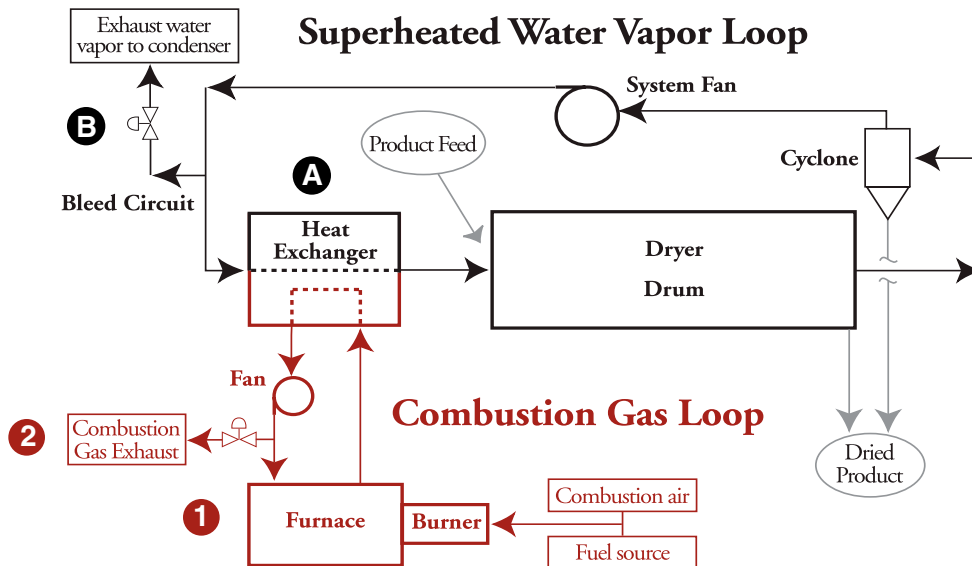
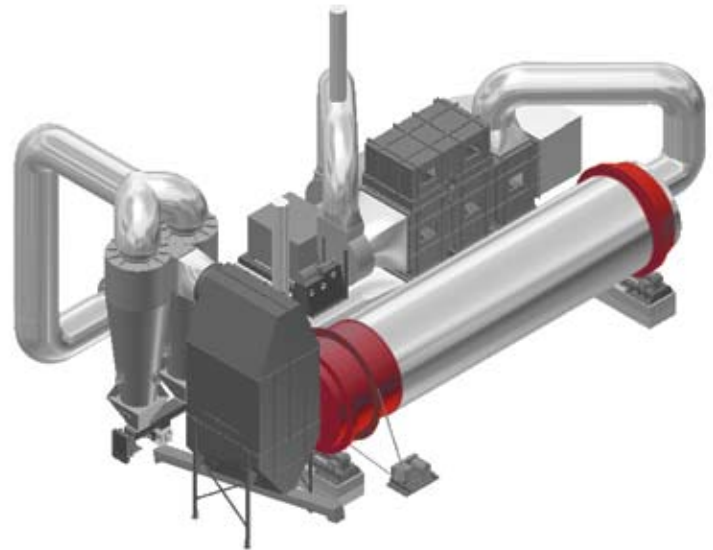

System fan creates a circulating loop of water vapor. Heat is transferred from the heat exchanger (A) to drive the evaporation of moisture from wet feed in the dryer drum. The water evaporated from the feed displaces air in the water vapor loop, creating the “airless” environment. To maintain atmospheric pressure in the dryer, a bleed circuit (B) is needed to exhaust water vapor. This water vapor can be treated with a conventional condensing system or used as a heat source for other processes.

Combustion gases from a conventional furnace (1) supply heat to the exchanger. The combustion gases are circulated several times through the heat exchanger for maximum efficiency before being exhausted into the atmosphere (2).

**The Dupps Company**



Germantown, Ohio U.S.A.

Phone: 937/855-6555

Fax: 937/855-6554

E-mail: info@dupps.com

Visit [www.dupps.com](http://www.dupps.com) to explore the world's leading protein recycling systems, equipment and service.

© 2016 The Dupps Company Printed in U.S.A.